



**PROPRIETARY NOTE**

THIS SPECIFICATION IS THE PROPERTY OF BOE DT AND SHALL NOT BE REPRODUCED OR COPIED WITHOUT THE WRITTEN PERMISSION OF BOE DT AND MUST BE RETURNED TO BOE DT UPON ITS REQUEST

**TITLE : MV270FHM-N20**

**Product Specification**

**Rev. P3**

Hefei Xinsheng Optoelectronics Technology Co.,LTD.

SPEC. NUMBER  
S864-8B016

PRODUCT GROUP  
TFT-LCD

Rev. P3

ISSUE DATE  
2016.12.27

PAGE  
1 OF 29

## REVISION HISTORY

( ) preliminary specification

(●) Final specification

Revision No.	Page	Description of changes	Date	Prepared
Rev.P0		Preliminary specification	2015.10.22	Wang Min
Rev.P1	P5 P9 P14 P29	Update weight Update the Reproduction of color Update the signal timing Update the position of product label	2016.01.06	Wang Min
Rev.P2	P11 P29	Update the position of product label	2016.12.05	Wang Min
Rev.P3	P19	Add Note5	2016.12.27	Wang Min

SPEC. NUMBER

S864-8B016

SPEC. TITLE

MV270FHM-N20 Product Specification Rev. P3

PAGE

2 OF 29

## Contents

<b>No.</b>	<b>Item</b>	<b>Page</b>
1.0	General Description	4
2.0	Absolute Maximum Ratings	6
3.0	Electrical Specifications	7
4.0	Optical Specifications	9
5.0	Interface Connection	11
6.0	Signal Timing Specifications	14
7.0	Signal Timing Waveforms of Interface Signal	16
8.0	Input Signals, Display Colors & Gray Scale of Colors	18
9.0	Power Sequence	19
10.0	Mechanical Characteristics	20
11.0	Reliability Test	21
12.0	Handling& Cautions	22
13.0	Product Serial Number	23
14.0	Packing	24
15.0	Appendix	26

### 1.0 GENERAL DESCRIPTION

#### 1.1 Introduction

MV270FHM-N20 is a color active matrix TFT LCD module using amorphous silicon TFT's (Thin Film Transistors) as an active switching devices. This module has a 27 inch diagonally measured active area with FHD resolutions (1920 horizontal by 1080 vertical pixel array). Each pixel is divided into RED, GREEN, BLUE dots which are arranged in vertical stripe and this module can display 16.7M colors. The TFT-LCD panel used for this module is adapted for a low reflection and higher color type.

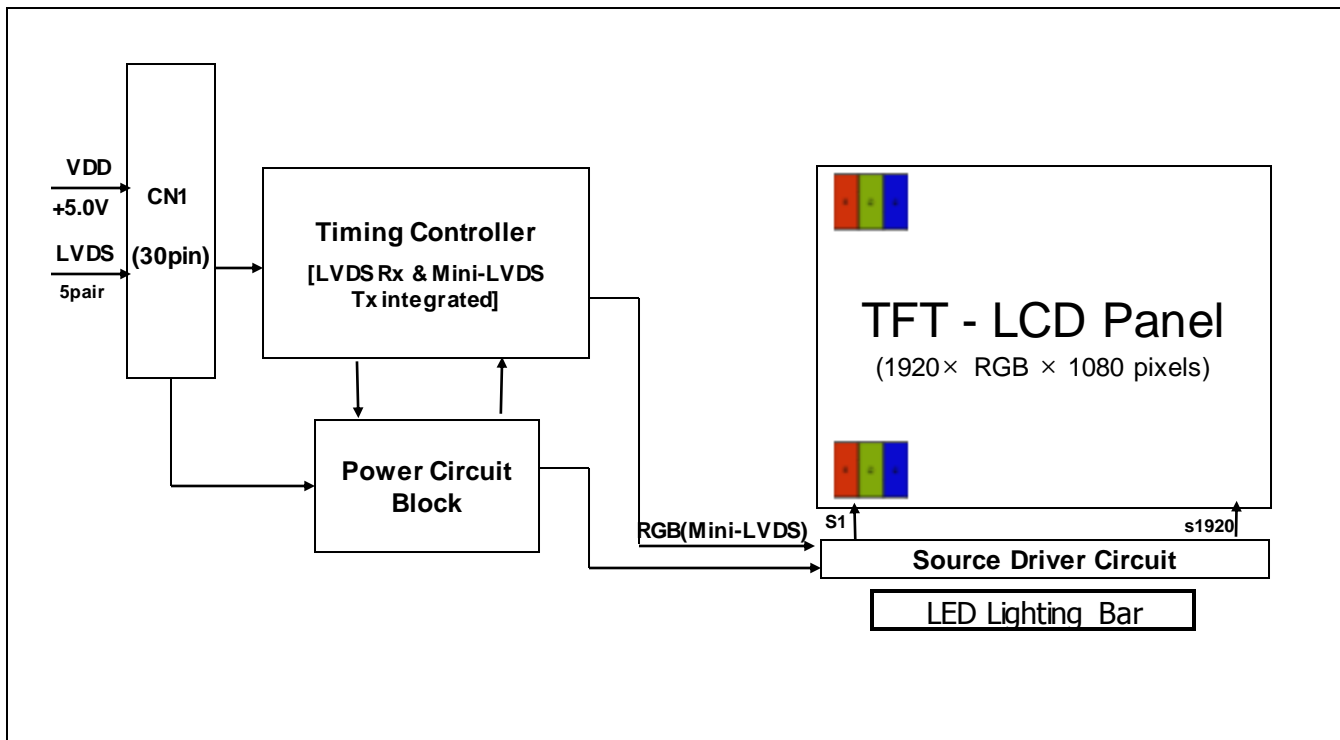

#### 1.2 Features

- LVDS Interface with 2 pixel / clock  
6-bit (Hi-FRC) color depth, display 16.7M B colors
- Compatible with Color Gamut 72%@NTSC(CIE 1931) and 83%@NTSC(CIE 1976)
- High luminance and contrast ratio, low reflection and wide viewing angle
- DE (Data Enable) only
- RoHS/Halogen Free
- TCO 7.0 , ES 7.0 compliant
- Gamma Correction
- Reverse type

### 1.3 Application

- Desktop Type of PC & Workstation Use
- Slim-Size Display for Stand-alone Monitor
- Display Terminals for Control System
- Monitors for Process Controller

### 1.4 General Specification

The followings are general specifications at the model MV270FHM-N20.

<Table 1. General Specifications>

Parameter	Specification	Unit	Remarks
Active area	597.888(H) × 336.312(V)	mm	
Number of pixels	1920(H) × 1080 (V)	pixels	
Pixel pitch	0.3114 (H) × 0.3114(V)	mm	
Pixel arrangement	RGB Vertical stripe		
Display colors	16.7M	colors	
Display mode	Normally Black		
Dimensional outline	611.5(H) × 355.8(V) × 13.2(Depth)	mm	Detail refer to drawing
Weight	3490	g	
Bezel width (L/R/U/D)	4.8/4.8/4.8/10.7	mm	
Surface Treatment	Haze 25%, 3H		
Back-light	Down side, 1-LED Lighting Bar type		

### 2.0 ABSOLUTE MAXIMUM RATINGS

The followings are maximum values which, if exceed, may cause faulty operation or damage to the unit. The operational and non-operational maximum voltage and current values are listed in Table 2.

< Table 2. Absolute Maximum Ratings >

[VSS=GND=0V]

Parameter	Symbol	Min.	Max.	Unit	Remarks
Power Supply Voltage	V <sub>DD</sub>	GND-0.3	6	V	Ta = 25 °C
Logic Supply Voltage	V <sub>IN</sub>	VSS-0.3	V <sub>DD</sub> +0.3	V	
Operating Temperature	T <sub>OP</sub>	0	+50	°C	1)
Storage Temperature	T <sub>ST</sub>	-20	+60	°C	1)

Note : 1) Temperature and relative humidity range are shown in the figure below.  
 Wet bulb temperature should be 39 °C max. and no condensation of water.

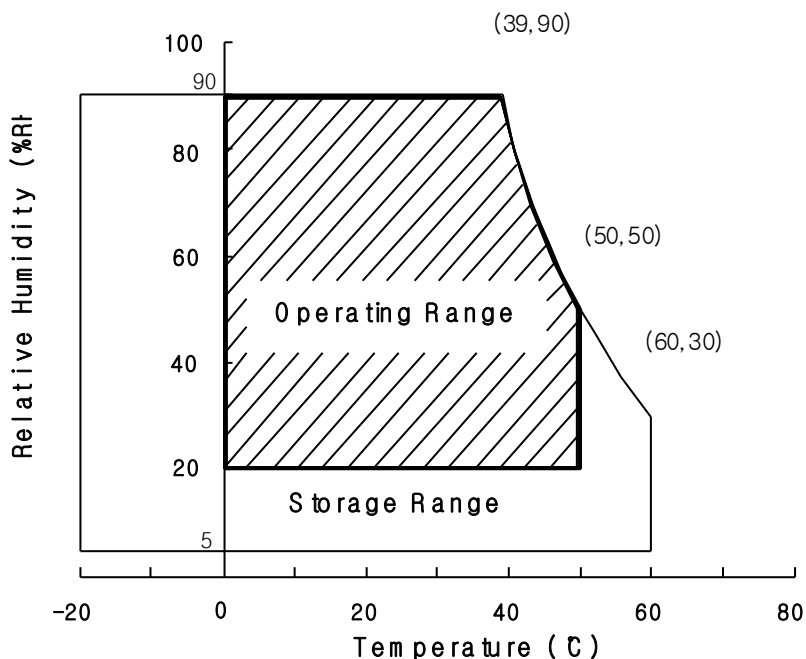

### 3.0 ELECTRICAL SPECIFICATIONS

#### 3.1 Electrical Specifications

< Table 3. Electrical specifications >

[Ta =25 ± 2 °C]

Parameter		Min.	Typ.	Max.	Unit	Remarks
Power Supply Voltage	V <sub>DD</sub>	4.5	5	5.5	V	Note1
Power Supply Current	I <sub>DD</sub>	-	640	1060	mA	
In-Rush Current	I <sub>RUSH</sub>	-	-	4.0	A	Note 2
Permissible Input Ripple Voltage	V <sub>RF</sub>	-	-	400	mV	Note1,3
High Level Differential Input Threshold Voltage	V <sub>IH</sub>	+100	-	+300	mV	
Low Level Differential Input Threshold Voltage	V <sub>IL</sub>	-300	-	-100	mV	
Differential input voltage	V <sub>ID</sub>	200	-	600	mV	
Differential input common mode voltage	V <sub>cm</sub>	1.0	1.2	1.5		V <sub>IH</sub> =100mV, V <sub>IL</sub> =-100mV
Power Consumption	P <sub>D</sub>	-	3.2	5.3	W	
	P <sub>BL</sub>	13.57	15.12	17.82	W	
	P <sub>total</sub>	-	18.32	23.12	W	

- Notes : 1. The supply voltage is measured and specified at the interface connector of LCM.  
 The current draw and power consumption specified is for VDD=5.0V, Frame rate=60Hz  
 Clock frequency = 74.3 MHz. Test Pattern of power supply current  
 a) Typ : Color Test  
 b) Max : Skip Subpixel255  
 c) Flicker Pattern

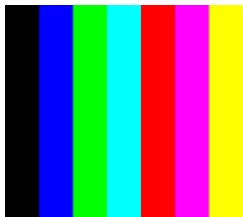

(a)

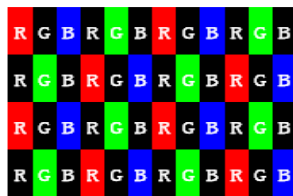

(b)

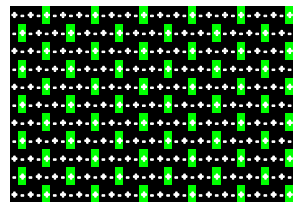

(c)

2. Duration of rush current is about 2 ms and rising time of VDD is 520 μs ± 20 %  
 3. Ripple Voltage should be covered by Input voltage Spec.  
 4. Calculated value for reference (Input pins\*VPIN × IPIN) excluding inverter loss.

**3.2 Backlight Unit**

&lt; Table 4. LED Backlight Unit &gt;

Parameter		Min.	Typ.	Max.	Unit	Remarks
LED Light Bar Input Voltage Per Input Pin	VPIN	52.2	54	59.4	V	Duty 100%
LED Light Bar Input Current Per Input Pin	IPIN	65	70	75	mA	Note1,2,
LED Power Consumption	P <sub>BL</sub>	13.57	15.12	17.82	W	Note 3
LED Life-Time	-	30,000	-	-	Hrs	Note 4

LED bar consists of 72 LED packages,4 strings(parallel)18packages(serial)

Note1: There are one light bar ,and the specified current is input LED chip 100% duty current

Note2: The sense current of each input pin is 70mA

Note3:  $P_{BL}=4\text{Input pins} \times VPIN \times IPIN$

Note4: The lifetime is determined as the time at which luminance of LED become 50% of the initial brightness or not normal lighting at IPIN=70mA on condition of continuous operating at  $25 \pm 2 \text{ } ^\circ\text{C}$



## 4.0 OPTICAL SPECIFICATION

### 4.1 Overview

The test of Optical specifications shall be measured in a dark room (ambient luminance  $\leq 1$  lux and temperature =  $25 \pm 2^\circ\text{C}$ ) with the equipment of Luminance meter system (Goniometer system and TOPCONE PR730) and test unit shall be located at an approximate distance 50cm from the LCD surface at a viewing angle of  $\theta$  and  $\Phi$  equal to  $0^\circ$ . We refer to  $\theta_{\Phi=0}$  ( $=\theta_3$ ) as the 3 o'clock direction (the "right"),  $\theta_{\Phi=90}$  ( $=\theta_{12}$ ) as the 12 o'clock direction ("upward"),  $\theta_{\Phi=180}$  ( $=\theta_9$ ) as the 9 o'clock direction ("left") and  $\theta_{\Phi=270}$  ( $=\theta_6$ ) as the 6 o'clock direction ("bottom"). While scanning  $\theta$  and/or  $\Phi$ , the center of the measuring spot on the Display surface shall stay fixed. The measurement shall be executed after 30 minutes warm-up period. VDD shall be 5.0V +/-10% at  $25^\circ\text{C}$ . Optimum viewing angle direction is 6 o'clock.

### 4.2 Optical Specifications

[VDD = 5.0V, Frame rate = 60Hz, Clock = 74.3MHz,  $I_{BL} = 280\text{mA}$ ,  $T_a = 25 \pm 2^\circ\text{C}$ ]

< Table 5. Module Optical >

Parameter		Symbol	Condition	Min.	Typ.	Max.	Unit	Remark
Viewing Angle range	Horizontal	$\theta_3$	CR > 10	85	89	-	Deg.	Note 1
		$\theta_9$		85	89	-	Deg.	
	Vertical	$\theta_{12}$		85	89	-	Deg.	
		$\theta_6$		85	89	-	Deg.	
Luminance Contrast ratio		CR		700	1000			Note 2
Luminance of White		$Y_w$		250	300		cd/m <sup>2</sup>	Note 3
White luminance uniformity		$\Delta Y$		75	80		%	Note 4
Reproduction of color	White	$W_x$	$\theta = 0^\circ$ (Center) Normal Viewing Angle	-0.03	0.313	+0.03	-	Note 5
		$W_y$			0.329		-	
	Red	$R_x$			0.640		-	
		$R_y$			0.340		-	
	Green	$G_x$			0.296		-	
		$G_y$			0.622		-	
	Blue	$B_x$			0.152		-	
		$B_y$			0.053		-	
Response Time	GTG	$T_g$			14	20	ms	Note 6
Cross Talk		CT		-	-	2.0	%	Note 7

**Note :**

1. Viewing angle is the angle at which the contrast ratio is greater than 10. The viewing are determined for the horizontal or 3, 9 o'clock direction and the vertical or 6, 12 o'clock direction with respect to the optical axis which is normal to the LCD surface.
2. Contrast measurements shall be made at viewing angle of  $\theta=0^\circ$  and at the center of the LCD surface. Luminance shall be measured with all pixels in the view field set first to white, then to the dark (black) state. (See FIGURE 1 shown in Appendix) Luminance Contrast Ratio (CR) is defined mathematically.

$$CR = \frac{\text{Luminance when displaying a white raster}}{\text{Luminance when displaying a black raster}}$$

3. Center Luminance of white is defined as the LCD surface. Luminance shall be measured with all pixels in the view field set first to white. This measurement shall be taken at the locations shown in FIGURE 2 for a total of the measurements per display.
4. The White luminance uniformity on LCD surface is then expressed as :  
 $\Delta Y = (\text{Minimum Luminance of 9points} / \text{Maximum Luminance of 9points}) * 100$   
 (See FIGURE 2 shown in Appendix).
5. The color chromaticity coordinates specified in Table 5. shall be calculated from the spectral data measured with all pixels first in red, green, blue and white. Measurements shall be made at the center of the panel.
6. Response time  $T_g$  is the average time required for display transition by switching the input signal as below table and is based on Frame rate  $f_V = 60\text{Hz}$  to optimize.  
 Each time in below table is defined as appendix Figure 3 and shall be measured by switching the input signal for "any level of gray(bright)" and "any level of gray(dark)"
7. Cross-Talk of one area of the LCD surface by another shall be measured by comparing the luminance ( $Y_A$ ) of a 25mm diameter area, with all display pixels set to a gray level, to the luminance ( $Y_B$ ) of that same area when any adjacent area is driven dark. (See FIGURE 4 shown in Appendix).

### 5.0 INTERFACE CONNECTION.

#### 5.1 LED Light Bar

-LED connector : 3709K-Q06N-00L manufactured by ENTERY , or Equivalent.

< Table 6. LED Light Bar >

Pin No.	Symbol	Description
1	FB1	Channel 1 Current Feedback
2	FB2	Channel 2 Current Feedback
3	VLED	LED Power Supply
4	VLED	LED Power Supply
5	FB3	Channel 3 Current Feedback
6	FB4	Channel 4 Current Feedback

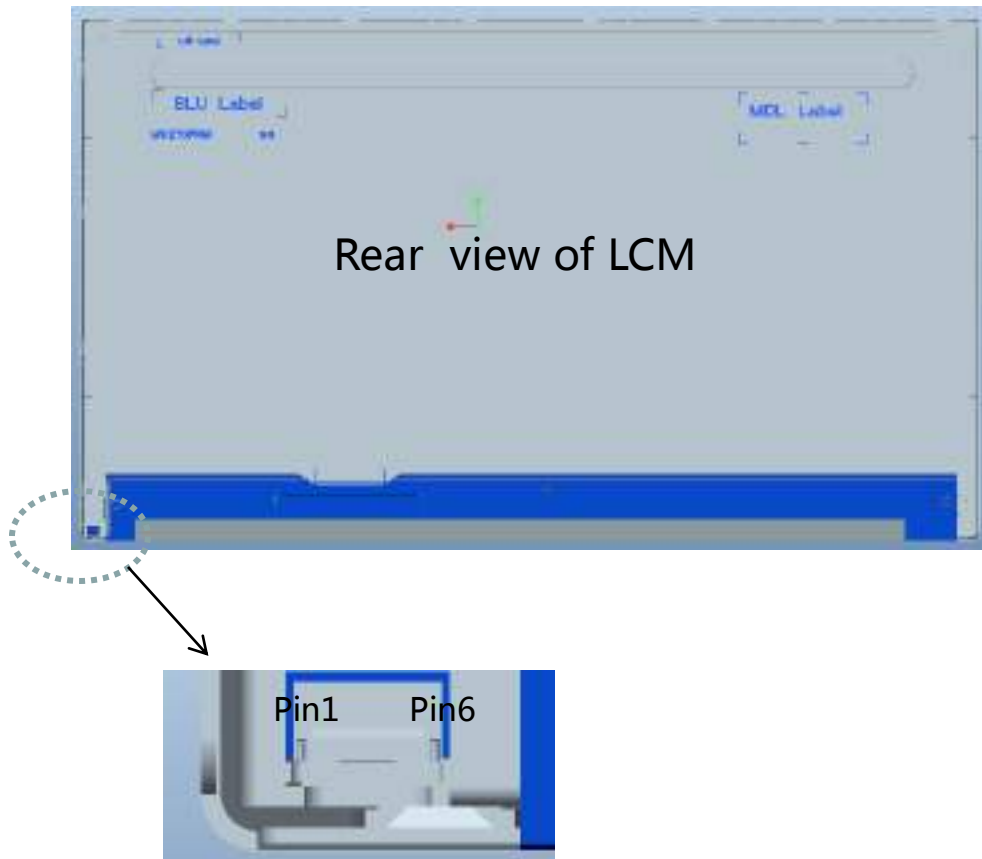

## 5.2 Electrical Interface Connection

- CN1 Module Side Connector : MSBKT2407P30HC

Pin No	Symbol	Function	Remark
1	RXO0N	Negative LVDS differential data input	
2	RXO0P	Positive LVDS differential data input	
3	RXO1N	Negative LVDS differential data input	
4	RXO1P	Positive LVDS differential data input	
5	RXO2N	Negative LVDS differential data input	
6	RXO2P	Positive LVDS differential data input	
7	BIST	BIST	
8	RXOCN-	Negative LVDS differential clock input	
9	RXOCP	Positive LVDS differential clock input	
10	RXO3N	Negative LVDS differential data input	
11	RXO3P	Positive LVDS differential data input	
12	RXE0N	Negative LVDS differential data input	
13	RXE0P	Positive LVDS differential data input	
14	GND	Ground	
15	RXE1N	Negative LVDS differential data input	
16	RXE1P	Positive LVDS differential data input	
17	GND	Ground	
18	RXE2N	Negative LVDS differential data input	
19	RXE2P	Positive LVDS differential data input	
20	RXECN	Negative LVDS differential clock input	
21	RXECP	Positive LVDS differential clock input	
22	RXE3N	Negative LVDS differential data input	
23	RXE3P	Positive LVDS differential data input	
24	GND	Ground	
25	SCL	I2C Clock (For VCOM tuning )	
26	SDA	I2C Data (For VCOM tuning)	
27	NC	NC	
28	VIN	Power Supply 5V	
29	VIN	Power Supply 5V	
30	VIN	Power Supply 5V	

**5.3 LVDS Interface (Tx; THC63LVDF83A or Equivalent)**

	Input Signal	Transmitter		Interface		HR230WU-400 (CN11)	Remark
		Pin No.	Pin No.	System (Tx)	TFT-LCD (Rx)	Pin No.	
LVDS	OR0	51	48 47	OUT0- OUT0+	RX00- RX00+	1	
	OR1	52					
	OR2	54					
	OR3	55					
	OR4	56				2	
	OR5	3					
	OG0	4	46 45	OUT1- OUT1+	RX01- RX01+	3	
	OG1	6					
	OG2	7					
	OG3	11					
	OG4	12				4	
	OG5	14					
	OB0	15	42 41	OUT2- OUT2+	RX02- RX02+	5	
	OB1	19					
	OB2	20					
	OB3	22					
	OB4	23				6	
	OB5	24					
	Hsync	27	8 9	CLK OUT- CLK OUT+	RXO CLK- RXO CLK+		
	Vsync	28					
	DE	30	38 37	OUT3- OUT3+	RX03- RX03+	10	
	MCLK	31					
	OR6	50				11	
	OR7	2					
	OG6	8					
OG7	10						
OB6	16						
OB7	18						
RSVD	25						

Note: The order of even data is same with old data.

**6.0 SIGNAL TIMING SPECIFICATION**

6.1 The MV270FHM-N20 is operated by the DE only.

Item	Symbols		Min	Typ	Max	Unit	Note
DCLK	Period	tCLK	10	13.45	25	ns	
	Frequency	fCLK	40	74.3	100	MHz	
Hsync	Period	tHP	1050	1100	1120	tCLK	
	Horizontal Valid	tHV	960	960	960	tCLK	
	Horizontal Blank	tHB	90	140	192	tCLK	tWH+tHBP+tHFP
	Frequency	fH	38	67.5	89.29	KHz	
	Width	tWH	16	32	48	tCLK	
	Horizontal Back Porch	tHBP	32	48	64		
	Horizontal Front Porch	tHFP	42	60	80		
Vsync	Period	tVP	1110	1126	1251	tHP	
	Vertical Valid	tVV	1080	1080	1080	tHP	
	Vertical Blank	tVB	30	45	171	tHP	tWV+tVBP+tVFP
	Frequency	fV	50	60	75	Hz	
	Width	tWV	2	4	16	tHP	
	Vertical Back Porch	tVBP	5	8	32	tHP	
	Vertical Front Porch	tVFP	23	33	123	tHP	
LVDS Receiver clock	Input spread spectrum ratio	SSr	-3%	-	+3%	%	

### 6.2 LVDS Rx Interface Timing Parameter

The specification of the LVDS Rx interface timing parameter is shown in Table 7.

<Table 7. LVDS Rx Interface Timing Specification>

Item	Symbol	Min	Typ	Max	Unit	Remark
CLKIN Period	tRCIP	11.9	12.9	15.6	nsec	
Input Data 0	tRIP1	-0.4	0.0	+0.4	nsec	
Input Data 1	tRIP0	tRCIP/7-0.4	tRCIP/7	tRCIP/7+0.4	nsec	
Input Data 2	tRIP6	2 × tRCIP/7-0.4	2 × tRCIP/7	2 × tRCIP/7+0.4	nsec	
Input Data 3	tRIP5	3 × tRCIP/7-0.4	3 × tRCIP/7	3 × tRCIP/7+0.4	nsec	
Input Data 4	tRIP4	4 × tRCIP/7-0.4	4 × tRCIP/7	4 × tRCIP/7+0.4	nsec	
Input Data 5	tRIP3	5 × tRCIP/7-0.4	5 × tRCIP/7	5 × tRCIP/7+0.4	nsec	
Input Data 6	tRIP2	6 × tRCIP/7-0.4	6 × tRCIP/7	6 × tRCIP/7+0.4	nsec	

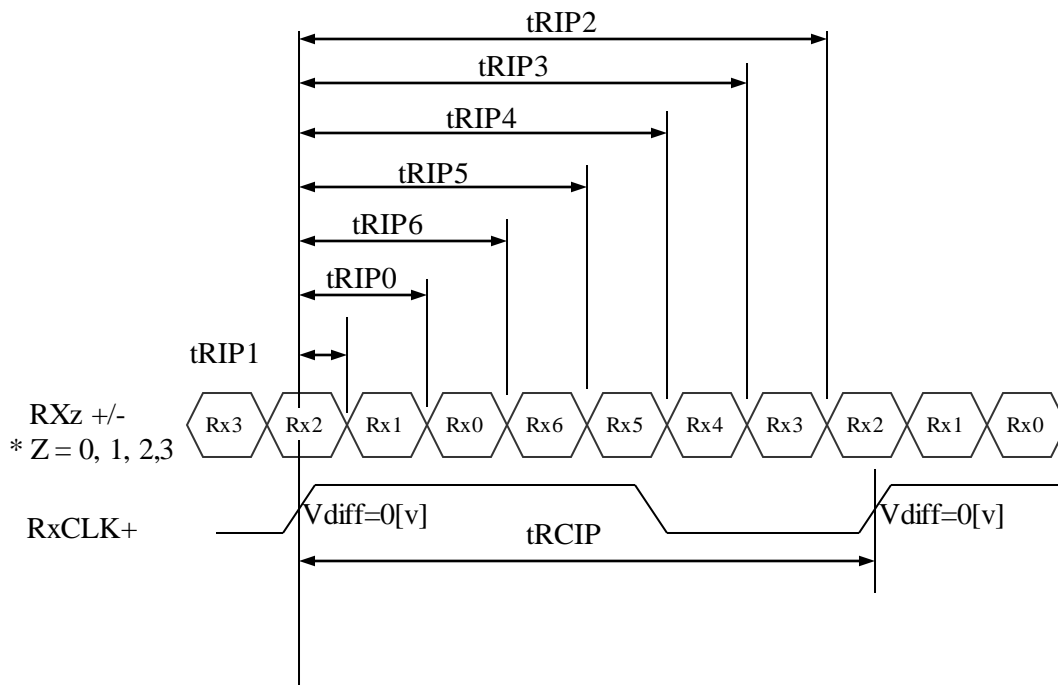

\*  $V_{diff} = (RXz+) - (RXz-), \dots, (RXCLK+) - (RXCLK-)$

## 7.0 SIGNAL TIMING WAVEFORMS OF INTERFACE SIGNAL

### 7.1 Sync Timing Waveforms

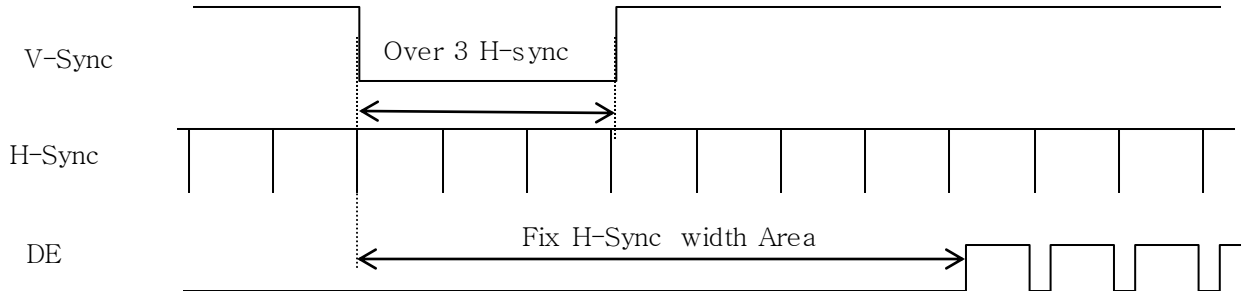

- 1) Need over 3 H-sync during V-Sync Low
- 2) Fix H-Sync width from V-Sync falling edge to first rising edge

### 7.2 Vertical Timing Waveforms

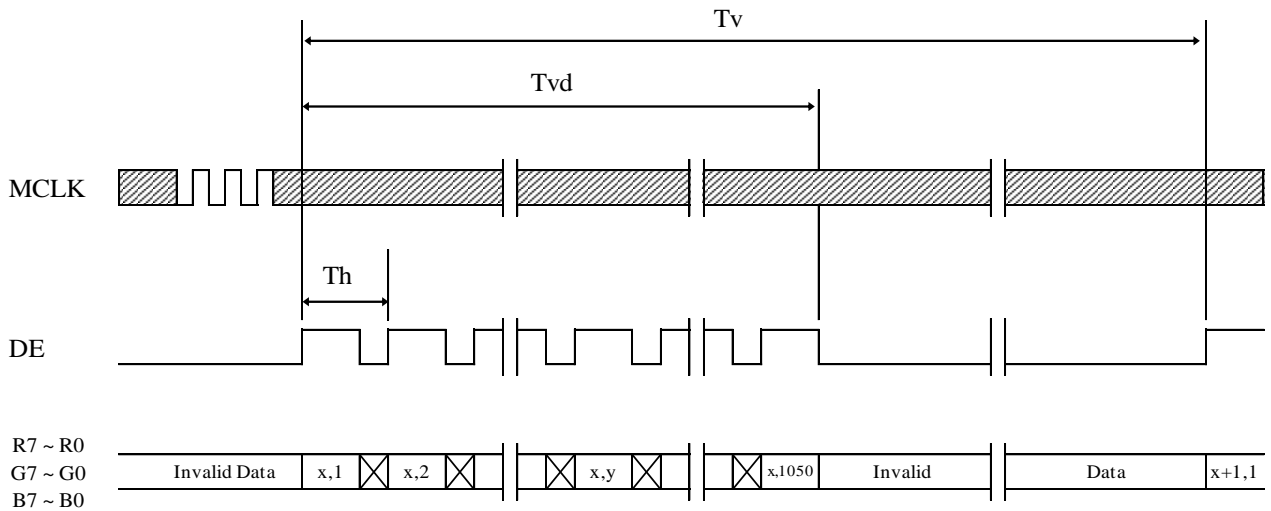



### 7.3 Horizontal Timing Waveforms

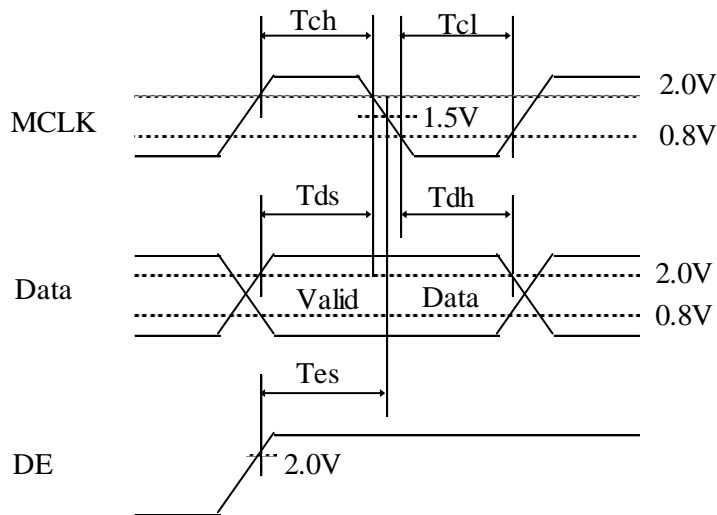
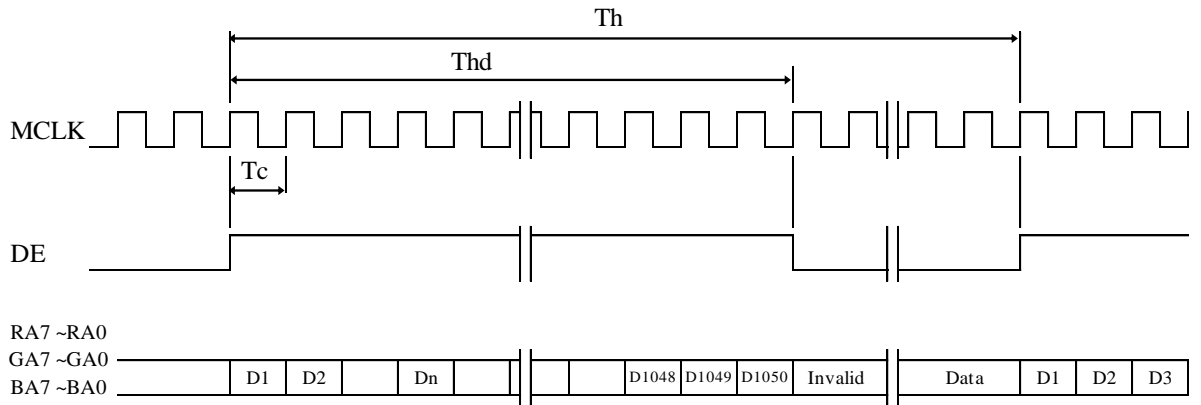

## 8.0 INPUT SIGNALS, BASIC DISPLAY COLORS & GRAY SCALE OF COLORS

Color & Gray Scale		RED DATA								GREEN DATA								BLUE DATA							
		R7	R6	R5	R4	R3	R2	R1	R0	G7	G6	G5	G4	G3	G2	G1	G0	B7	B6	B5	B4	B3	B2	B1	B0
Basic Colors	Black	0	0	0	0	0	0	0	0	0	0	0	0	0	0	0	0	0	0	0	0	0	0	0	0
	Blue	0	0	0	0	0	0	0	0	0	0	0	0	0	0	0	0	1	1	1	1	1	1	1	1
	Green	0	0	0	0	0	0	0	0	1	1	1	1	1	1	1	1	0	0	0	0	0	0	0	0
	Cyan	0	0	0	0	0	0	0	0	1	1	1	1	1	1	1	1	1	1	1	1	1	1	1	1
	Red	1	1	1	1	1	1	1	1	0	0	0	0	0	0	0	0	0	0	0	0	0	0	0	0
	Magenta	1	1	1	1	1	1	1	1	0	0	0	0	0	0	0	0	1	1	1	1	1	1	1	1
	Yellow	1	1	1	1	1	1	1	1	1	1	1	1	1	1	1	1	0	0	0	0	0	0	0	0
	White	1	1	1	1	1	1	1	1	1	1	1	1	1	1	1	1	1	1	1	1	1	1	1	1
Gray Scale of RED	Black	0	0	0	0	0	0	0	0	0	0	0	0	0	0	0	0	0	0	0	0	0	0	0	0
	△	0	0	0	0	0	0	0	1	0	0	0	0	0	0	0	0	0	0	0	0	0	0	0	0
	Darker	0	0	0	0	0	0	1	0	0	0	0	0	0	0	0	0	0	0	0	0	0	0	0	0
	△	↑								↑								↑							
	▽	↓								↓								↓							
	Brighter	1	1	1	1	1	1	0	1	0	0	0	0	0	0	0	0	0	0	0	0	0	0	0	0
	▽	1	1	1	1	1	1	1	0	0	0	0	0	0	0	0	0	0	0	0	0	0	0	0	0
	Red	1	1	1	1	1	1	1	1	0	0	0	0	0	0	0	0	0	0	0	0	0	0	0	0
Gray Scale of GREEN	Black	0	0	0	0	0	0	0	0	0	0	0	0	0	0	0	0	0	0	0	0	0	0	0	0
	△	0	0	0	0	0	0	0	0	0	0	0	0	0	0	0	1	0	0	0	0	0	0	0	0
	Darker	0	0	0	0	0	0	0	0	0	0	0	0	0	0	1	0	0	0	0	0	0	0	0	0
	△	↑								↑								↑							
	▽	↓								↓								↓							
	Brighter	0	0	0	0	0	0	0	0	1	1	1	1	1	1	0	1	0	0	0	0	0	0	0	0
	▽	0	0	0	0	0	0	0	0	1	1	1	1	1	1	1	0	0	0	0	0	0	0	0	0
	Green	0	0	0	0	0	0	0	0	1	1	1	1	1	1	1	1	0	0	0	0	0	0	0	0
Gray Scale of BLUE	Black	0	0	0	0	0	0	0	0	0	0	0	0	0	0	0	0	0	0	0	0	0	0	0	0
	△	0	0	0	0	0	0	0	0	0	0	0	0	0	0	0	0	0	0	0	0	0	0	0	1
	Darker	0	0	0	0	0	0	0	0	0	0	0	0	0	0	0	0	0	0	0	0	0	0	1	0
	△	↑								↑								↑							
	▽	↓								↓								↓							
	Brighter	0	0	0	0	0	0	0	0	0	0	0	0	0	0	0	0	1	1	1	1	1	1	0	1
	▽	0	0	0	0	0	0	0	0	0	0	0	0	0	0	0	0	1	1	1	1	1	1	1	0
	Blue	0	0	0	0	0	0	0	0	0	0	0	0	0	0	0	0	1	1	1	1	1	1	1	1
Gray Scale of WHITE	Black	0	0	0	0	0	0	0	0	0	0	0	0	0	0	0	0	0	0	0	0	0	0	0	0
	△	0	0	0	0	0	0	0	1	0	0	0	0	0	0	0	1	0	0	0	0	0	0	0	1
	Darker	0	0	0	0	0	0	1	0	0	0	0	0	0	0	1	0	0	0	0	0	0	0	1	0
	△	↑								↑								↑							
	▽	↓								↓								↓							
	Brighter	1	1	1	1	1	1	0	1	1	1	1	1	1	1	0	1	1	1	1	1	1	1	0	1
	▽	1	1	1	1	1	1	1	0	1	1	1	1	1	1	1	0	1	1	1	1	1	1	1	0
	White	1	1	1	1	1	1	1	1	1	1	1	1	1	1	1	1	1	1	1	1	1	1	1	1

### 9.0 POWER SEQUENCE

To prevent a latch-up or DC operation of the LCD module, the power on/off sequence shall be as shown in below

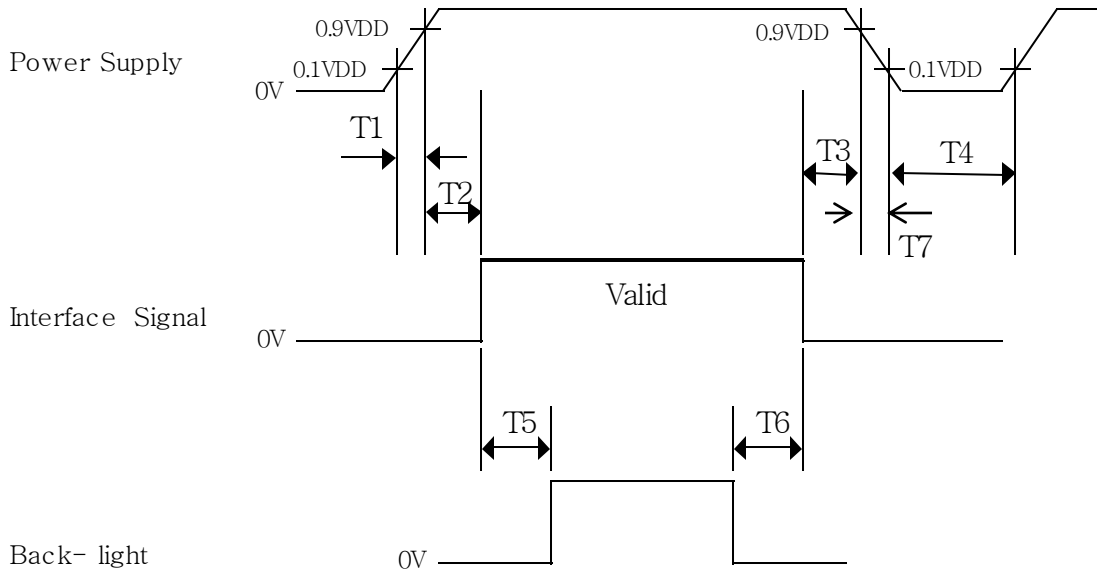

- $0.5\text{ ms} \leq T1 \leq 10\text{ ms}$
- $0 \leq T2 \leq 50\text{ ms}$
- $0 \leq T3 \leq 50\text{ ms}$
- $1\text{ sec} \leq T4$
- $200\text{ ms} \leq T5$
- $200\text{ ms} \leq T6$

#### Notes:

1. When the power supply VDD is 0V, keep the level of input signals on the low or keep high impedance.
2. Do not keep the interface signal high impedance when power is on.
3. Back Light must be turn on after power for logic and interface signal are valid.
4. T7 decreases smoothly, there is none re-bouncing voltage.
5. During Mode change ( Resolution, frequency, timing, sleep mode, Color depth change, etc. ) the logic power/back- light/interface signal should be turned off as shown above; after the changing, power on as shown above.

## 10.0 MECHANICAL CHARACTERISTICS

### 10.1 Dimensional Requirements

FIGURE 6 (located in Appendix) shows mechanical outlines for the model MV270FHM-N20. Other parameters are shown in Table 8.

<Table 8. Dimensional Parameters>

Parameter	Specification	Unit
Dimensional outline	611.5(H) × 355.8(V) × 13.2(Depth)	mm
Weight	3490	gram
Active area	597.888(H) × 336.312(V)	mm
Pixel pitch	0.3114 (H) × 0.3114(V)	mm
Number of pixels	1920(H)×1080 (V) (1 pixel = R + G + B dots)	pixels
Back-light	Down side, 1-LED Lighting Bar type	

### 10.2 Anti-Glare and Polarizer Hardness.

The surface of the LCD has an anti-glare coating to minimize reflection and a coating to reduce scratching.

### 10.3 Light Leakage

There shall not be visible light from the back-lighting system around the edges of the screen as seen from a distance 50cm from the screen with an overhead light level of 350lux.

**11.0 RELIABILITY TEST**

The Reliability test items and its conditions are shown in below.

<Table 9 Reliability Test Parameters >

No	Test Items	Conditions	
1	High temperature storage test	Ta = 60 °C, 240 hrs	
2	Low temperature storage test	Ta = -20 °C, 240 hrs	
3	High temperature & high humidity operation test	Ta = 50 °C, 80%RH, 240hrs	
4	High temperature operation test	Ta = 50 °C, 240hrs	
5	Low temperature operation test	Ta = 0°C, 240hrs	
6	Thermal shock	Ta = -20 °C ↔ 60 °C (0.5 hr), 100 cycle	
7	Vibration test (non-operating)	Frequency	Random, 10 ~ 300 Hz, 30 min/Axis
		Gravity / AMP	1.5 Grms
		Period	X, Y, Z 30 min
8	Shock test (non-operating)	Gravity	50G
		Pulse width	11msec, Half sine wave
		Direction	± X, ± Y, ± Z Once for each
9	Electro-static discharge test	Air : 150 pF, 330Ω, 15 KV	Contact : 150 pF, 330Ω, 8 KV

## 12.0 HANDLING & CAUTIONS

- (1) Cautions when taking out the module
  - Pick the pouch only, when taking out module from a shipping package.
- (2) Cautions for handling the module
  - As the electrostatic discharges may break the LCD module, handle the LCD module with care. Peel a protection sheet off from the LCD panel surface as slowly as possible.
  - As the LCD panel and back - light element are made from fragile glass material, impulse and pressure to the LCD module should be avoided.
  - As the surface of the polarizer is very soft and easily scratched, use a soft dry cloth without chemicals for cleaning.
  - Do not pull the interface connector in or out while the LCD module is operating.
  - Put the module display side down on a flat horizontal plane.
  - Handle connectors and cables with care.
- (3) Cautions for the operation
  - When the module is operating, do not lose CLK, ENAB signals. If any one of these signals is lost, the LCD panel would be damaged.
  - Obey the supply voltage sequence. If wrong sequence is applied, the module would be damaged.
- (4) Cautions for the atmosphere
  - Dew drop atmosphere should be avoided.
  - Do not store and/or operate the LCD module in a high temperature and/or humidity atmosphere. Storage in an electro-conductive polymer packing pouch and under relatively low temperature atmosphere is recommended.
- (5) Cautions for the module characteristics
  - Do not apply fixed pattern data signal to the LCD module at product aging.
  - Applying fixed pattern for a long time may cause image sticking.
- (6) Other cautions
  - Do not disassemble and/or re-assemble LCD module.
  - Do not re-adjust variable resistor or switch etc.
  - When returning the module for repair or etc., Please pack the module not to be broken. We recommend to use the original shipping packages.

### 13.0 PRODUCT SERIAL NUMBER

MV270FHM-N20

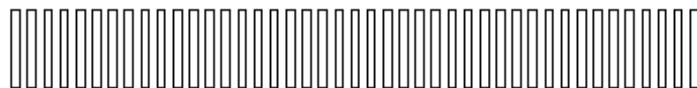

DP/N XXXXXX

XXXXXXXXXXXXXXXXXX

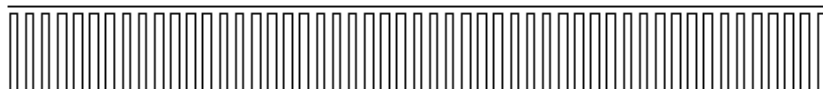

REV XXX

XXXXXXXXXXXXXXXXXX



MADE IN CHINA

#### MDLID Naming Rule:

Code \ Digit	1	2	3	4	5	6	7	8	9	10	11	12	13	14	15	16	17
Code	S	L	S	5	1	2	3	5	9	4	2	0	0	0	1	D	B
Description	Model Code /GBN		Grade	Line	Year		Month	Model Extension Code (Last 4 Digits Of FGCD)				Serial No 00001-ZZZZZZ					

## 14.0 Packing

### 14.1 Packing Order

Put pad into the box



Place the modules bundled by packing bag into the box, 6pcs module per box, put a cover on the top of the box

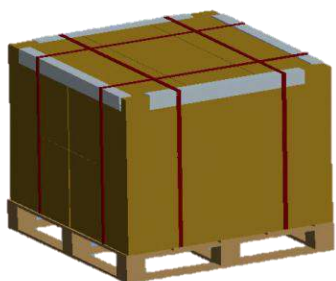

12ea box per pallet

After sealing the box, put the box on the pallet



### 14.2 Packing Note

- Box Dimension : TBD
- Package Quantity in one Box : 6pcs

### 14.3 Box label

- Label Size : 110 mm (L) × 55mm (W)
- Contents  
 Model : MV270FHM-N20  
 Q`ty : Module \* Q`ty in one box  
 Serial No. : Box Serial No.  
 Date : Packing Date

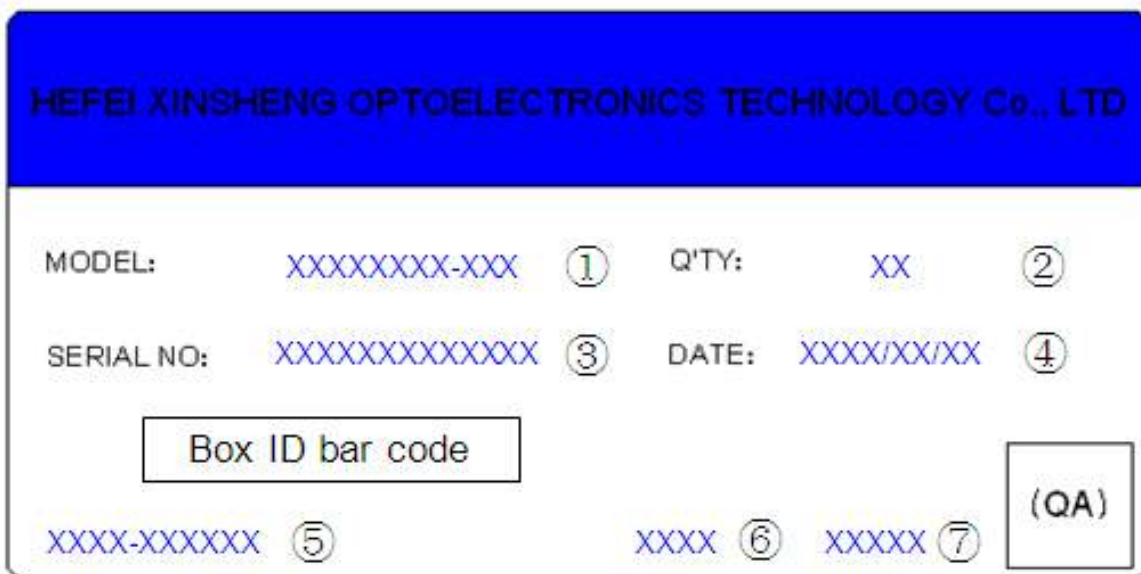

The printed part follow as:

- |                                  |                 |
|----------------------------------|-----------------|
| 1. FG-CODE                       | 2. Quantity     |
| 3. Box ID                        | 4. Packing Date |
| 4. Customer Code                 |                 |
| 8. FG-CODE(the last four number) |                 |
| 7. Vendor Code                   |                 |

## 15.0 APPENDIX

**Figure 1. Measurement Set Up**

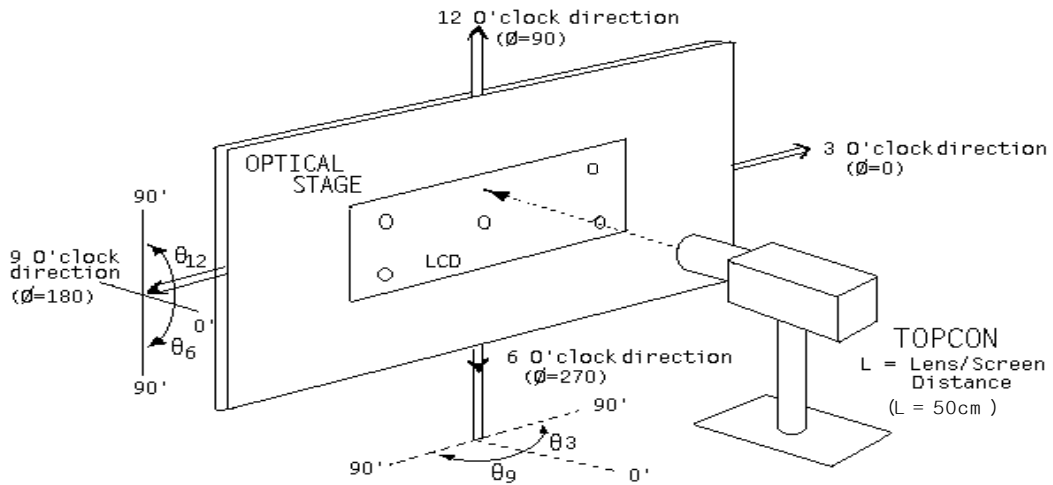

**Figure 2. White Luminance and Uniformity Measurement Locations (9 points)**

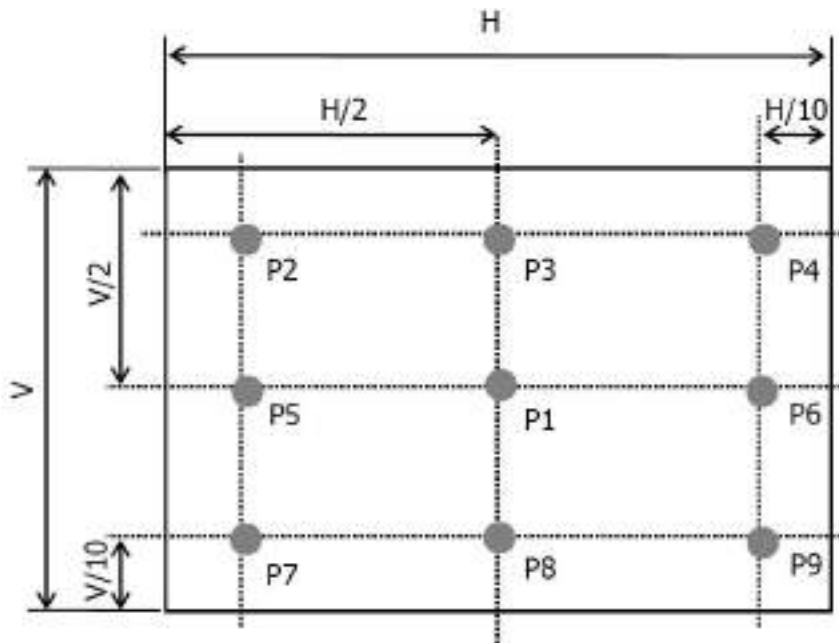

**Figure 3. Response Time Testing**



**Figure 4. Cross Modulation Test Description**

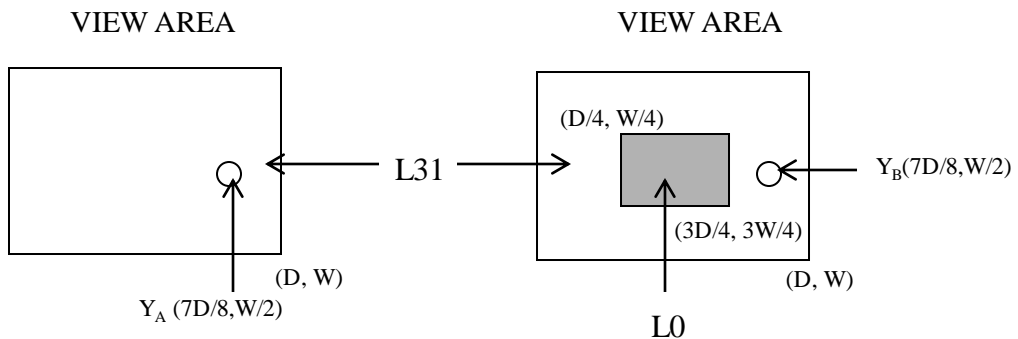

$$\text{Cross-Talk (\%)} = \left| \frac{Y_B - Y_A}{Y_A} \right| \times 100$$

Where:  $Y_A$  = Initial luminance of measured area (cd/m<sup>2</sup>)  
 $Y_B$  = Subsequent luminance of measured area (cd/m<sup>2</sup>)  
 The location measured will be exactly the same in both patterns

**Figure 5. TFT-LCD Module Outline Dimensions (Front view)**

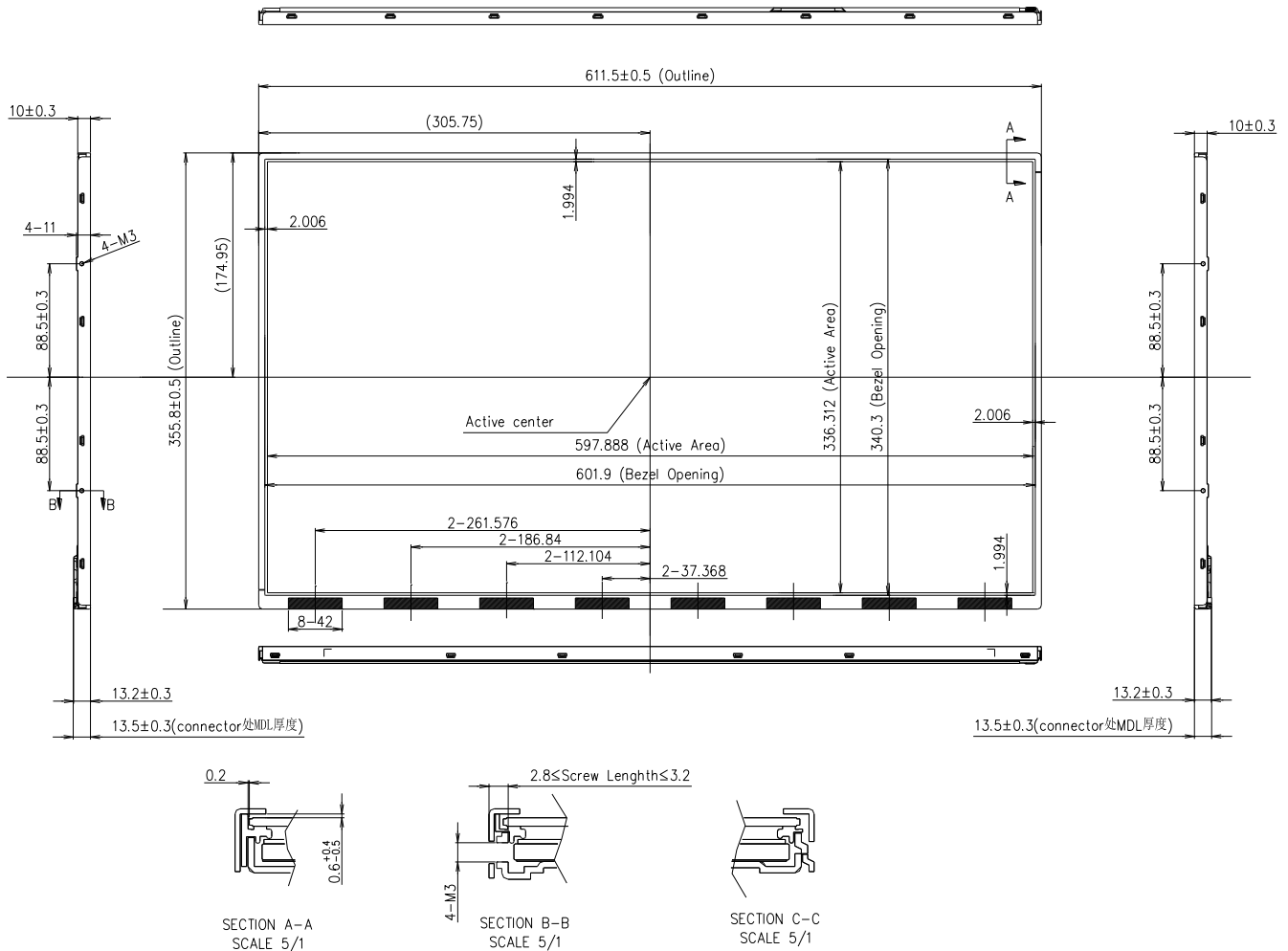

**Figure 6. TFT-LCD Module Outline Dimensions (Rear view)**

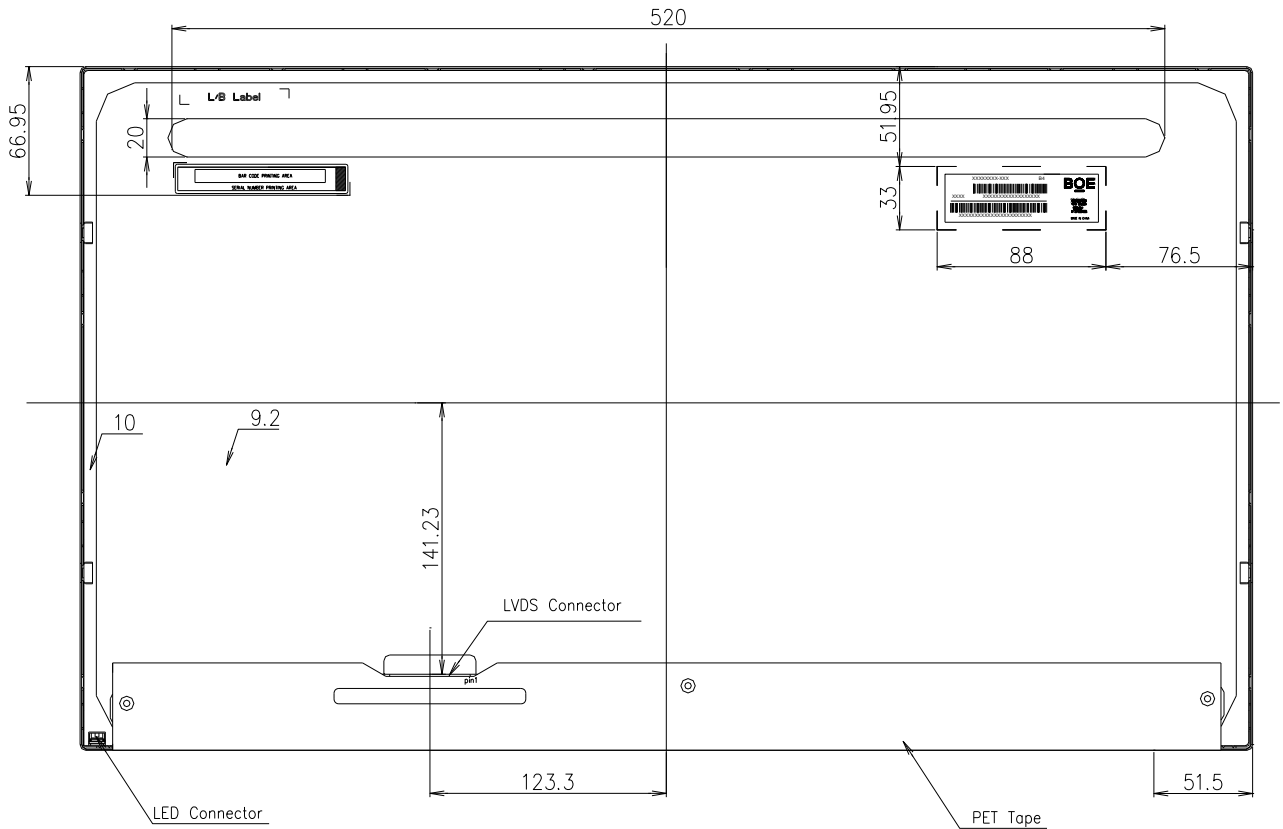

**NOTE:**

1. I/F CONNECTOR SPECIFICATION  
FI-XB30SSL-HF15 (JAE) or IS100-L300-C23 (UJU)
2. LED CONNECTOR SPECIFICATION: 3709K-Q06N-00L or Equivalent
3. Tilt and portial disposition tolerance of display area as following
  - (1)Y-direction: 佛A-B佛 $\leq 1.4$
  - (2)X-direction: 佛C-D佛 $\leq 1.4$

